

Wide adjustment range for all positions, satisfy demand for different surgeries

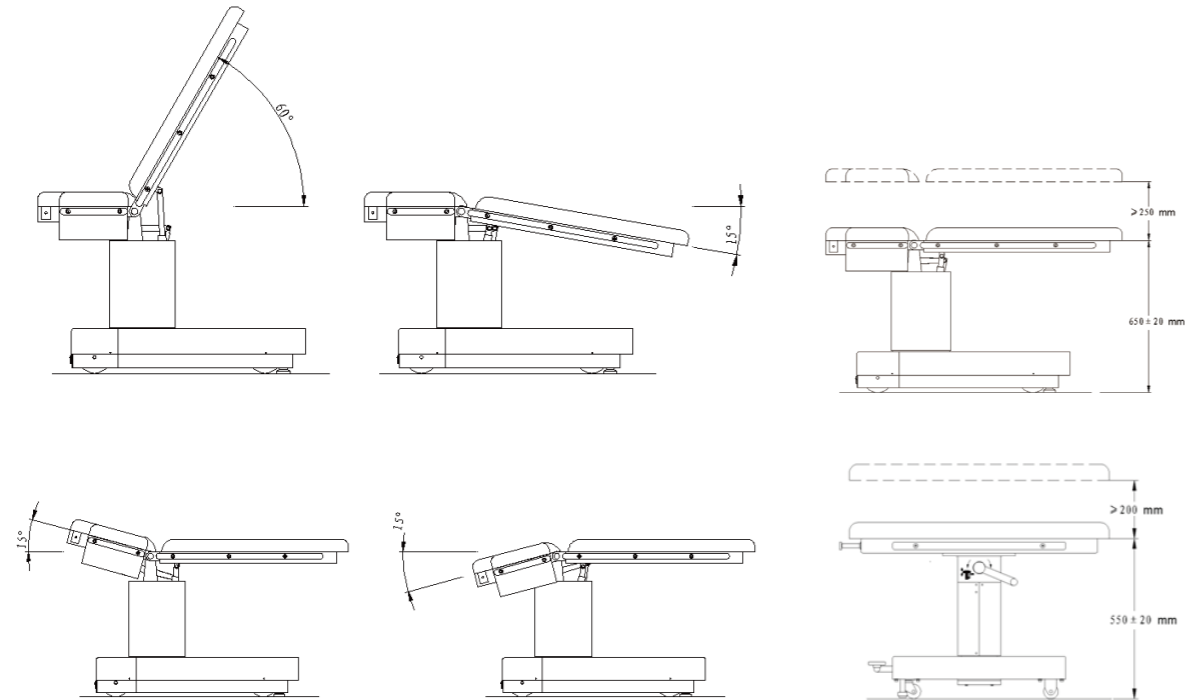

Technical Specifications

Length	2,160 (mm)
Width (without side rails)	660 (mm)
Height for body section (without pads)	650 to 900 (250±20) (mm)
Height for legs section (without pads)	550 to 750 (200±20) (mm)
Seat plate up / down	15° / 15°
Back plate up / down	60° / 15°
Weight capacity for body section	170Kg
Weight capacity for legs section	100Kg



OP650

Electronic Delivery Table

CE

AEOMED
Reliable Quality Thoughtful Service

HQ: 11B2, Fengtai Science Park, Beijing, China (100070)
Science Park: No. 10, Chaobai Street, Yanjiao Development Zone, Sanhe City, Hebei Province, China (065201)
TEL: +86-10-5841 1198 FAX: +86-10-6371 8989
Http: //www.aeonmed.com E-mail: marketing@aeonmed.com

The information contained in this leaflet is correct at the date of publication. The policy of Beijing Aeonmed Co., Ltd. is one of the continued improvement to its products. Because of this policy, Aeonmed reserves the right to make any change, which may affect the information in this leaflet without giving prior notices.
AOP650-1812

AEOMED
Reliable Quality Thoughtful Service

OP650

is a electronic delivery table fully meeting the doctor's requirement during operation.
It offers high load capacity, flexibility & comfort to pregnant woman in delivery room.



Feature

- Linear actuators, it has strong loading capacity, simple operation and stable.
- The mattress is made of polyurethane sponge, it's antibacterial, durable and waterproof.
- Built-in charger adapter.
- Integrated control system.

- Stainless steel frame and table top
- Removable/ Adjustable auxiliary table (leg part)
- Three heavy duty conductive swivel caster
- Hand controller and foot controller
- Locking system

